



POSTAL BOOK PACKAGE 2027

MECHANICAL ENGINEERING

OBJECTIVE PRACTICE SETS VOLUME - III

CONTENTS

► Theory of Machines 1-109

1. Planer Mechanisms	2 - 14
2. Displacement, Velocity and Acceleration	15 - 25
3. Cams	26 - 31
4. Gear and Gear Trains	32 - 51
5. Dynamic Analysis of Slider Crank	52 - 58
6. Flywheel	59 - 65
7. Mechanical Vibrations	66 - 91
8. Governors	92 - 99
9. Balancing and Gyroscope	100- 109

► Strength of Materials 110-251

1. Properties of Materials	111 - 117
2. Simple Stress-strain and Elastic Constants	118 - 136
3. SFD and BMD	137 - 154
4. Principal Stress and Strain & Theories of Failure	155 - 169
5. Deflection of Beams	170 - 188
6. Bending Stresses in Beams	189 - 204
7. Shear Stresses in Beams	205 - 213

8. Thick and Thin Cylinders and Spheres	214 - 220
9. Torsion of Shafts	221 - 234
10. Theory of Columns	235 - 243
11. Shear Centre	244 - 247
12. Theory of Spring	248 - 251

► Machine Design 252-332

1. Static and Variable Loading	253 - 267
2. Riveted, Bolted and Welded Joints	268 - 282
3. Bearings	283 - 294
4. Clutches	295 - 300
5. Gears	301 - 309
6. Brakes, Flywheel and Springs	310 - 318
7. Shafts	319 - 324
8. Threaded joints, Power screw, Belts	325 - 332



THEORY OF MACHINES

OBJECTIVE PRACTICE SETS

Page No. 1 - 109

Planer Mechanisms

MCQ and NAT Questions

Q.1 Refer to the figure given below

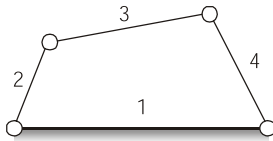

If 2 and 4 are given rotatory motion the motion of link 3 is

- (a) pure translation
- (b) pure rotation
- (c) translation and rotation
- (d) Not defined

Q.2 A higher pair can be replaced by a

- (a) two revolute pair and two additional linkages
- (b) two revolute pair and one additional linkage
- (c) one revolute pair and one additional linkage
- (d) None of these

Q.3 Refer to the figure given below

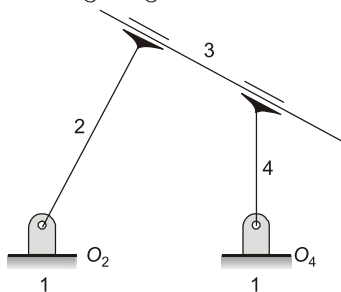

The effective degree of freedom of the given figure is

- (a) one
- (b) zero
- (c) three
- (d) indefinite

Q.4 Refer to the figure given below

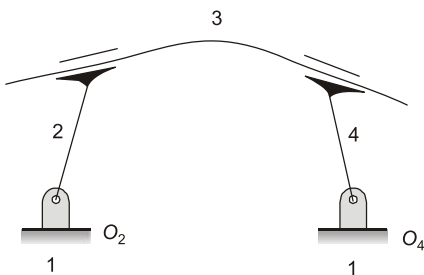

The degree of freedom of the given figure is

- (a) one
- (b) two
- (c) zero
- (d) three

Q.5 The degree of freedom of the given mechanism is

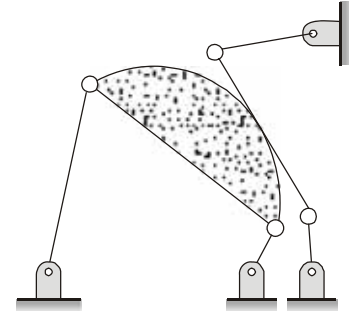

- (a) 1
- (b) 2
- (c) 3
- (d) ∞

Q.6 Which of the following is an exact straight line mechanism?

- (a) Watt's Mechanism
- (b) Grasshopper's Mechanism
- (c) Peaucellier Mechanism
- (d) Robert's Mechanism

Q.7 Which one of following is an Open Pair?

- (a) Ball and socket joint
- (b) Journal bearing
- (c) Lead screw and nut
- (d) Cam and follower

Q.8 The instantaneous centre of motion of rigid-thin disc-wheel rolling on plane rigid surface shown in the figure, is located at the point

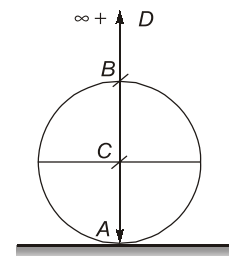

- (a) A
- (b) B
- (c) C
- (d) D

Q.9 A linkage is shown below in the figure in which links ABC and DEF are ternary links whereas AF, BE and CD are binary links

The quick return ratio of the mechanism is

- (a) 3.0 (b) 2.75
(c) 2.5 (d) 2.0

Q.21 Watt's indicator mechanism which is an inversion of four bar chain, shown below. The links CE and BFD acts as

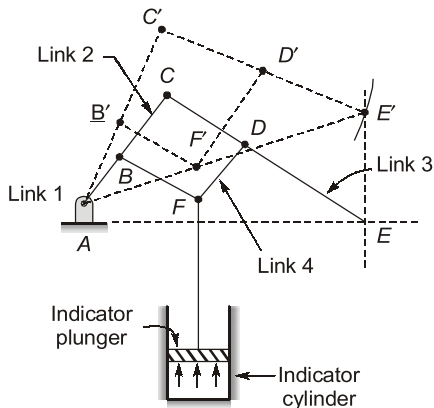

- (a) Two cranks
(b) CE as crank and BFD as lever
(c) CE as lever and BFD as crank
(d) CE and BFD both as levers

Q.22 The relation between the number of links (l) and the number of binary joints (j) for a kinematic chain having constrained motion is given by $j + h/2 = 3l/2 - 2$. If the left hand side is greater than right hand side, then the chain is

- (a) locked chain
(b) completely constrained chain
(c) successfully constrained chain
(d) incompletely constrained chain

Q.23 The given figure of lazy tong mechanism has the degree of freedom

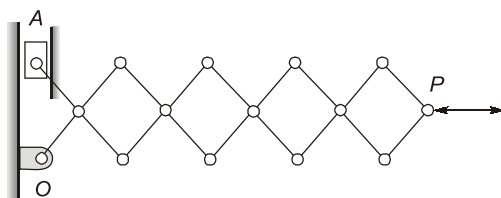

- (a) 0 (b) 1
(c) 2 (d) 3

Q.24 Which of the following pair is incorrect?

- (a) Peaucellier's Mechanism – exact straight line
(b) Grass-Hopper Mechanism – Modified Scott Russel Mechanism
(c) Lazy tong Mechanism – Parallel linkages
(d) Crosby indicator – Horizontal line

Q.25 Consider the following statements regarding the kinematic linkage shown below:

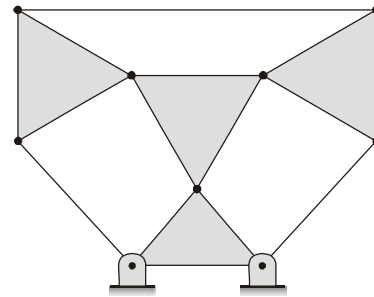

- Number of binary links is 3
 - Number of ternary links is 4
 - Degree of freedom of this mechanism is 1
- Which of these statements are correct?
- (a) 1 and 2 (b) 2 and 3
(c) 1 and 3 (d) 1, 2 and 3

Q.26 The four bar mechanism shown in the figure (Given : $OA = 3$ cm, $AB = 5$ cm, $BC = 6$ cm, $OC = 7$ cm) is a

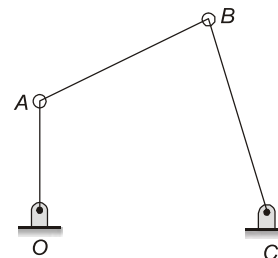

- (a) Double crank mechanism
(b) Double rocker mechanism
(c) Crank rocker mechanism
(d) Single slider mechanism

Q.27 The driving and driven shafts connected by a Hooke's joint will have equal speeds if

- (a) $\sin \theta = \pm \tan \alpha$
(b) $\tan \theta = \pm \sqrt{\cos \alpha}$
(c) $\tan \theta = \pm \sqrt{\sin \alpha}$
(d) $\cot \theta = \pm \sqrt{\cos \alpha}$

Q.28 In a Hooke's joint the maximum fluctuation of speed is approximately equal to

- (a) $\omega \alpha$ (b) $\frac{\omega}{\alpha}$
(c) $\omega \alpha^2$ (d) $\omega^2 \alpha$

Q.29 Angle between line of transmission with horizontal known as

- (a) Deviation angle

Q.53 Statement (I): The given line diagram of Watt's indicator mechanism is a type of crank and lever mechanism.

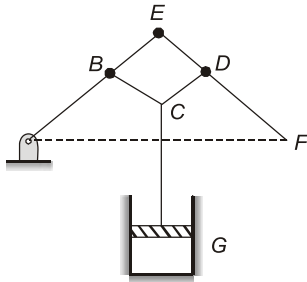

Statement (II): BCD acts as a lever.

Q.54 Statement (I): An inversion is obtained by fixing in turn different links in a kinematic chain.

Statement (II): Quick return mechanism is derived from a single slider crank chain by fixing the ram of a shaper with the slotted lever through a link.

Q.55 Statement (I): In a kinematic chain we obtain a definite output for an input.

Statement (II): In a kinematic chain the first link is connected to the last link and all the relative motions in the chain are constrained.

Multiple Select Questions (MSQ)

Q.56 In a crank and slotted lever quick return motion mechanism, the distance between the fixed centers is 240 mm and the length of the driving crank is 120 mm. The length of the slotted bar is 450 mm. Which of the following statements is(are) correct, if the line of stroke passes through the extreme positions of the free end of the lever?

- Inclination of the slotted bar with the vertical is 60° .
- Inclination of the slotted bar with the vertical is 30° .
- Time ratio of cutting stroke to the return stroke is 2.
- The length of the stroke is 450 mm.

Q.57 Which of the following statements is(are) the inversions of double slider crank chain?

- Elliptical trammel.
- Whitworth quick return motion mechanism.
- Scotch Yoke mechanism
- Oldham's coupling

Q.58 A four bar mechanism is shown in figure with the length of different links as shown.

Which of the following statements is(are) correct for this four bar mechanism?

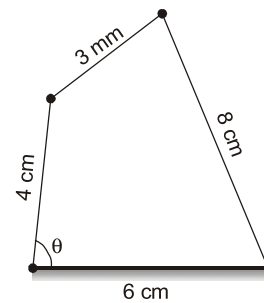

- For maximum value of transmission angle $\theta = 180^\circ$.
- For minimum value of transmission angle $\theta = 0^\circ$.
- Maximum value of transmission angle is 124.23° .
- Minimum value of transmission angle is 46.57° .



Answers Planer Mechanisms

- | | | | | | | | | |
|---------|---------------|---------------|---------------|-----------|-------------|---------|-------------|---------|
| 1. (c) | 2. (b) | 3. (b) | 4. (a) | 5. (a) | 6. (c) | 7. (d) | 8. (a) | 9. (a) |
| 10. (a) | 11. (c) | 12. (d) | 13. (d) | 14. (b) | 15. (d) | 16. (a) | 17. (a) | 18. (b) |
| 19. (c) | 20. (d) | 21. (d) | 22. (a) | 23. (b) | 24. (d) | 25. (a) | 26. (c) | 27. (b) |
| 28. (c) | 29. (a) | 30. (b) | 31. (b) | 32. (a) | 33. (d) | 34. (d) | 35. (d) | 36. (a) |
| 37. (d) | 38. (c) | 39. (a) | 40. (c) | 41. (c) | 42. (c) | 43. (b) | 44. (39.06) | 45. (1) |
| 46. (4) | 47. (360) | 48. (421.8) | 49. (533.3) | 50. (120) | 51. (34.92) | 52. (c) | 53. (d) | 54. (c) |
| 55. (a) | 56. (b, c, d) | 57. (a, c, d) | 58. (a, c, d) | | | | | |

Explanations Planer Mechanisms

1. (c)

If link 2 and 4 are given rotatory motion, then the motion of link 3 in the mechanism is neither purely translatory nor purely rotatory. It is a combination of translation and rotation which we normally say the link is in general motion.

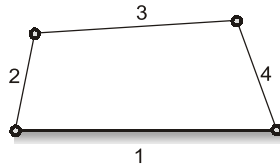

2. (b)

A higher pair can be replaced by a two revolute pair and one additional linkage
Example:

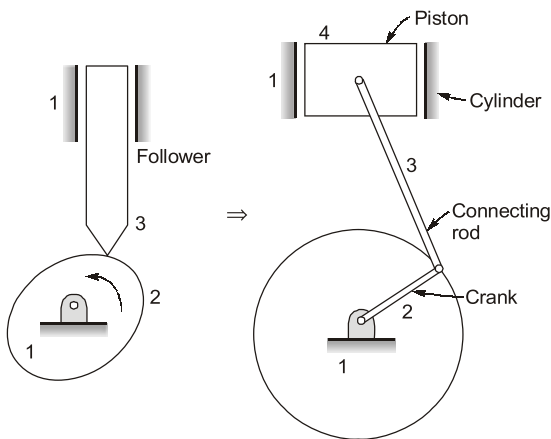

Here H.P. between link 2 and 3 is replaced by 2 L.P. (revolute pair) with one additional linkage.

3. (b)

Degree of freedom,

$$F = 3(l - 1) - 2j - h - F_r$$

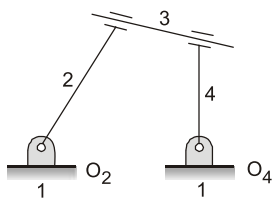

where, l = number of links; j = number of lower pair (binary joints); h = number of higher pair
 F_r = number of those motions which are not the part of mechanism (redundant motions)

$$F = 3(4 - 1) - 2 \times 4 - 0 - 1 = 0$$

So, the effective degree of freedom is zero.

4. (a)

Here $F_r = 0$
i.e. no redundant motion

$$\begin{aligned} \text{So, } F &= 3(l - 1) - 2j - h - F_r \\ &= 3(4 - 1) - 2 \times 4 = 1 \end{aligned}$$

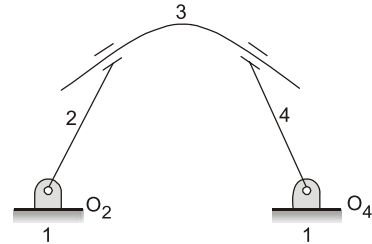

Note: The degree of freedom of given figure is 1, but still it is structure.

5. (a)

The mechanism has a cam pair. Therefore, its degree of freedom must be found from Gruebler's criterion.

Total number of links (l) = 7

Number of lower pairs (j) = 8

Number of higher pairs (h) = 1

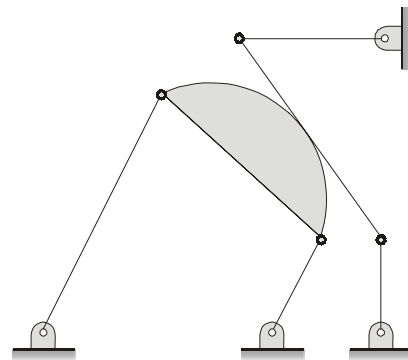

$$\begin{aligned} F &= 3(l - 1) - 2j - h \\ &= 3(7 - 1) - 2 \times 8 - 1 = 1 \end{aligned}$$

Thus, it is a mechanism with one degree of freedom.

6. (c)

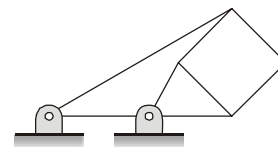

An exact straight line mechanism guides a reciprocating part in an exact straight line. On the other hand, an approximate straight-line mechanism is designed in such a way that the middle and the

STRENGTH OF MATERIALS

OBJECTIVE PRACTICE SETS

Page No. 110 - 251

Properties of Materials

MCQ and NAT Questions

- Q.1** In a tensile test, near the elastic limit zone
- tensile stress increases at a faster rate
 - tensile stress decreases at a faster rate
 - tensile stress increases in linear proportion to the strain
 - tensile stress decreases in linear proportion to the strain

- Q.2** Consider the following statements:
- Mild steel is more elastic than rubber.
 - Young's modulus of a material is used to represent the elasticity of the material.
 - Greater the Young's modulus, greater the elasticity.

Which of the above statement(s) is/are correct?

- Only 2
 - 1 and 3
 - 2 and 3
 - 1, 2 and 3
- Q.3** Which of the following properties is more sensitive to increase in strain rate?
- Yield strength
 - Elastic limit
 - Proportional limit
 - Tensile strength

- Q.4** The stress-strain diagram for two materials A and B is shown below:

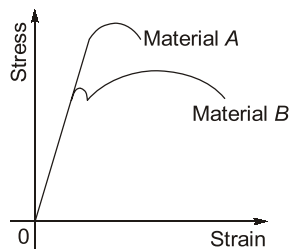

The following statements are made based on this diagram:

- Material A is more brittle than material B.
- The ultimate strength of material B is more than that of A.

With reference to the above statements, which of the following applies?

- Both the statements are false
 - Both the statements are true
 - I is true but II is false
 - I is false but II is true
- Q.5** As soon as the external forces causing deformation in a perfectly elastic body, are withdrawn, the elastic deformation disappears
- only partially
 - completely over a prolonged period of time
 - completely and instantaneously
 - completely after an initial period of rest

- Q.6** Consider the following statements:
- Strain-softening region in stress strain curve is also known as post ultimate stress.
 - Logarithmic strain given as $\bar{\epsilon} = \ln\left(\frac{L_f}{L_0}\right)$ is same as true strain.
 - Value of elastic modulus is a definite property of a material.

Which of the above statements is(are) INCORRECT?

- 1 and 3
 - 2 only
 - 1 only
 - None of these
- Q.7** An initially rectangular element of a material is deformed as shown in figure. The shear strain for the element (γ_{xy}), will be

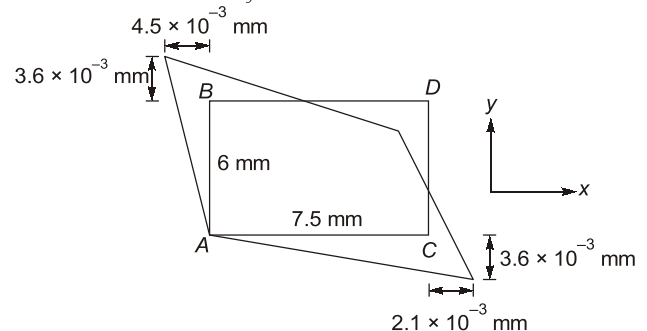

- 1370×10^{-6}
- 1500×10^{-6}
- 1230×10^{-6}
- 900×10^{-6}

Q.8 Due to change in temperature, the deformation in cuboid element is

- (a) same in perpendicular directions only
- (b) different in perpendicular directions
- (c) same in all directions
- (d) different in all directions

Q.9 If ϵ is engineering strain in a tensile specimen. The value of true strain (ϵ_t) is given as

- (a) ϵ
- (b) $e^\epsilon - 1$
- (c) $\ln(1 + \epsilon)$
- (d) $\left(\frac{1-\epsilon}{6}\right)$

Q.10 The stress strain behaviour of a material is as shown in figure below. Its modulus of resilience and toughness in Nm/m^3 are respectively:

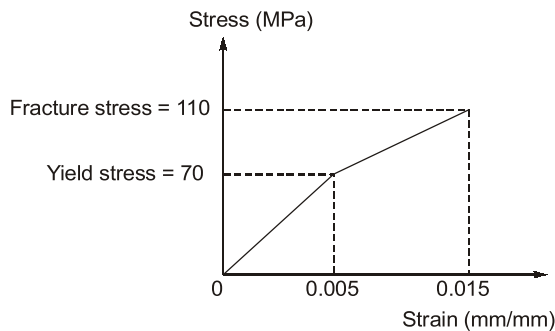

- (a) 20×10^4 and 107.5×10^4
- (b) 17.5×10^4 and 107.5×10^4
- (c) 17.5×10^4 and 120×10^4
- (d) 35×10^4 and 140×10^4

Q.11 In a material under a state of plane strain, a 10×10 mm square centered at a point gets deformed as shown in the figure.

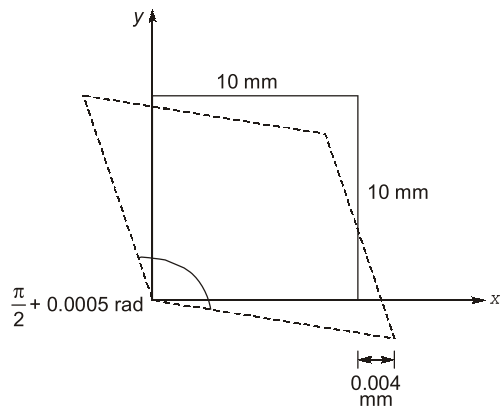

If the shear strain γ_{xy} at this point is expressed as $0.001 k$ (in rad), the value of k is

- (a) 0.50
- (b) 0.25
- (c) -0.25
- (d) -0.50

Q.12 The stress-strain curve for mild steel is shown in figure given below. Choose the correct option referring to both figure and table.

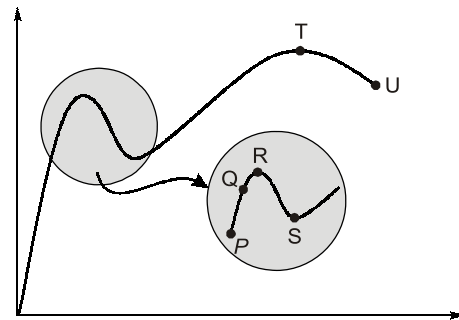

Point on the graph	Description of the point
P.	1. Upper yield point
Q.	2. Ultimate tensile strength
R.	3. Proportionality limit
S.	4. Elastic limit
T.	5. Lower yield point
U.	6. Failure

- (a) P-1, Q-2, R-3, S-4, T-5, U-6
- (b) P-3, Q-1, R-4, S-2, T-6, U-5
- (c) P-3, Q-4, R-1, S-5, T-2, U-6
- (d) P-4, Q-1, R-5, S-2, T-3, U-6

Q.13 A hypothetical engineering stress-strain curve shown in the figure has three straight lines PQ , QR , RS with coordinates $P(0, 0)$, $Q(0.2, 100)$, $R(0.6, 140)$ and $S(0.8, 130)$. Q is the yield point, R is the UTS point and S the fracture point.

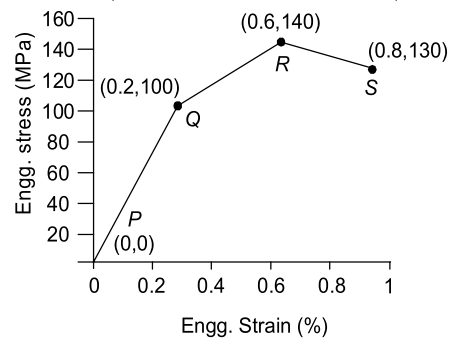

The toughness of the material (in MJ/m^3) is ____.

Q.14 Which of the following are incorrect statements?

- 1. Linear elastic range in compression is larger as compared to that in tension for most brittle materials.
- 2. The brittle fracture is performed by separation and is not accompanied by noticeable plastic deformation.

Select the correct answer using the codes given below.

- (a) 1-2-3-4 (b) 1-2-4-3
(c) 2-1-4-3 (d) 3-1-2-4

Q.24 The following observation refer to two metal specimens 'A' and 'B' of the same size subjected to uni-axial tension test upto failure.

- The elastic strain energy of A is more than that of B.
- Area under stress strain curve of A is less than that of B.
- The yield strength of A is more than that of B.
- The percentage elongation of A and B at elastic limit are equal.

Which of the following statements is true in this regard?

- (a) Specimen A is more ductile than specimen B.
(b) Specimen B is more ductile than specimen A.
(c) The ductility of two specimens are equal.
(d) The data is insufficient to compare the ductilities of the two specimens.

Q.25 A steel bar of length 3 m has yield stress 250 MPa and the slope of linear part of stress-strain curve is 190 GPa. The bar is loaded axially until it elongates 6 mm and then the load is removed. What is the residual strain in bar?

- (a) 0.002 (b) 0.00131
(c) 0.00069 (d) None of these

Q.26 The initial diameter of a cylindrical test specimen is 30 mm. During plastic deformation stage, it shows a diameter of 27 mm. Assuming the specimen is ductile material. The true longitudinal strain is _____ (Answer up to two decimal place)

Q.27 Consider the following statements regarding tension test of a specimen:

- Gauge length for specimen is $5.65\sqrt{A}$, where A is cross-sectional area of specimen.
- True rupture stress is much more than nominal rupture stress in specimen.
- For steel specimen, proportionality limit is more than elastic limit.
- Steel specimen breaks at ultimate stress.

Which of the above statements are CORRECT?

- (a) 1 and 2 (b) 1 and 3
(c) 2, 3 and 4 (d) 3 and 4

Multiple Select Questions (MSQ)

Q.28 Consider the following statements with reference to ductile materials and choose the correct statement(s) :

- (a) Large deformation is possible before absolute failure by rupture takes place.
(b) In ductile material, elastic deformation is more predominant than plastic one.
(c) Drawn permanently with great changes of shape without rupture.
(d) It can be beaten or rolled into plates.

Q.29 Which of the following statements is(are) correct?

- (a) The greatest strain energy stored in a body is called proof resilience.
(b) The quantity of strain energy stored in a body when strained upto elastic limit is called proof resilience.
(c) The least energy stored in a body is called proof resilience.
(d) Ability to absorb mechanical energy upto failure is called toughness.



Answers Properties of Materials

1. (c) 2. (d) 3. (b) 4. (c) 5. (c) 6. (c) 7. (c) 8. (d) 9. (c) 10. (b)
11. (d) 12. (c) 13. (0.85) 14. (d) 15. (a) 16. (d) 17. (b) 18. (b) 19. (c) 20. (b)
21. (a) 22. (b) 23. (b) 24. (b) 25. (c) 26. 0.21 27. (a) 28. (a, c) 29. (a, b, d)

Explanations Properties of Materials

2. (d)

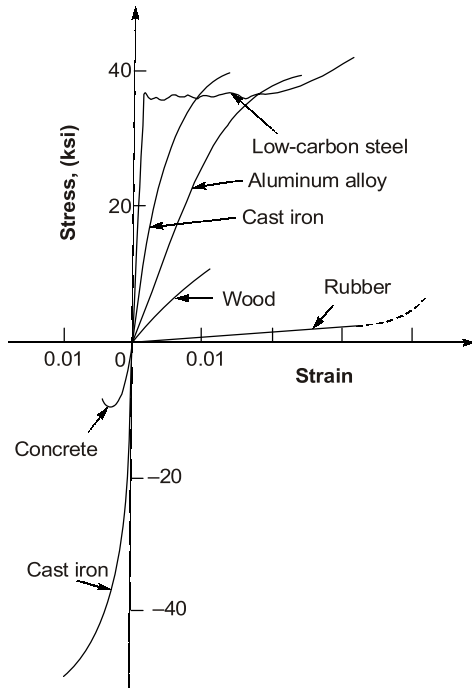

4. (c)

Since strain in material B is more, hence it is more ductile than material A i.e., material A is more brittle than material B. Hence **statement I is true**. Material A can reach upto higher stress level hence ultimate strength of material A is more than that of material B. Hence **statement II is false**.

5. (c)

For perfectly elastic body, ideal deformation takes place. Ideal deformation means that the deformation takes place instantaneously upon application of force and disappears completely and instantaneously on the removal of force.

6. (c)

Strain-softening region in stress strain curve is also known as post ultimate stress.

7. (c)

The shear strain is angle of distortion (change in angle of a corner of element) measured in radian. For corner A,

$$\gamma_{xy} = \frac{3.6 \times 10^{-3}}{7.5} + \frac{4.5 \times 10^{-3}}{6} = 1230 \times 10^{-6}$$

9. (c)

True strain for finite increment of loading such that length changes from L_0 to L is given by

$$\epsilon_t = \int_{L_0}^L \frac{dL}{L} = \ln\left(\frac{L}{L_0}\right)$$

$$\epsilon_t = \ln\left(\frac{L_0 + \delta}{L_0}\right) = \ln\left[1 + \frac{\delta}{L_0}\right]$$

$$\epsilon_t = \ln(1 + \epsilon)$$

10. (b)

$$\text{Resilience} = \frac{1}{2} \times 70 \times 0.005 \times 10^6$$

$$= 7.5 \times 10^4 \text{ Nm/m}^3$$

$$\text{Toughness} = 17.5 \times 10^4 + \left\{ \frac{(70+110)}{2} \right\} \times 0.01 \times 10^6$$

$$= 107.5 \times 10^4 \text{ Nm/m}^3$$

11. (d)

According to the sign convention,

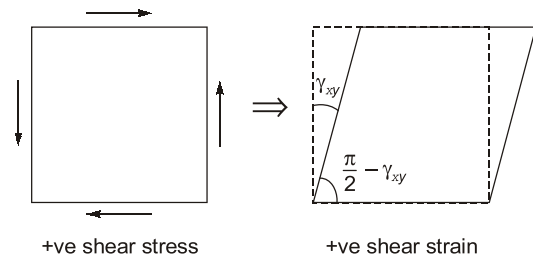

In question since angle has been increase therefore shear strain should be negative.

$$\therefore \gamma_{xy} = -0.0005 \text{ rad}$$

$$= 0.001k$$

$$-0.0005 = 0.001k$$

$$\Rightarrow k = -0.50$$

12. (c)

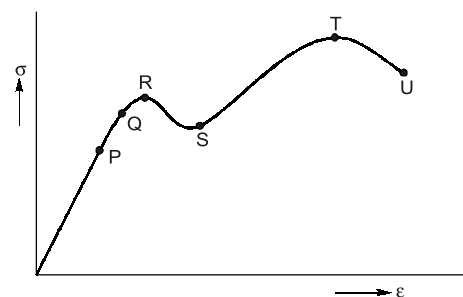

P : Proportional limit

Q : Elastic limit

R : Upper Yield Point

S : Lower Yield Point

T : Ultimate Tensile Strength

U : Failure/Rupture

13. (0.85)

Toughness is area of curve upto S on strain axis

$$\left[\frac{1}{2} \times \frac{0.2}{100} \times 100 \right] + \left\{ \frac{[100 + 140]}{2} \times \frac{0.4}{100} \right\} + \left\{ \frac{140 + 130}{2} \right\} \times \frac{0.2}{100}$$

$$= 0.1 + 0.48 + 0.27 = 0.85 \text{ MJ/m}^3$$

14. (d)

Brittle materials (in compression test): Brittle material in compression typically an initial linear region followed by a region in which the shortening increases at a higher rate than does the load for cast iron, the shape may be like this:

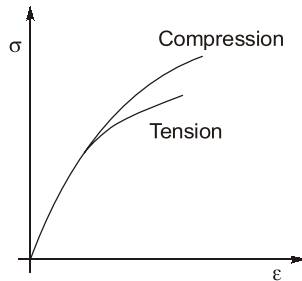

Brittle material in compression behave elastically upto certain load, and then fail suddenly by splitting or by cracking in the way as shown in figure, thus brittle fracture is performed by separation and is not accompanied by noticeable plastic deformation.

15. (a)

Visco-elastic material exhibit a mixture of creep and elastic after effects at room temperature. Thus their behaviour is time dependent materials with different properties in different directions are called Anisotropic orthotropic material is a special case of an anisotropic material in three mutually perpendicular directions. However there are symmetric about any axis.

16. (d)

Given, $P = 18 \text{ kN} = 18000 \text{ N}$

$$A_0 = \frac{\pi}{4} d^2 = \frac{\pi}{4} (9.6)^2 = 72.38 \text{ mm}^2$$

$$l_0 = 400 \text{ mm}$$

$$l'_0 = 401.5 \text{ mm}$$

$$\sigma = \frac{P}{A_0} = \frac{18000}{72.38} = 249 \text{ MPa}$$

$$\epsilon = \frac{\Delta l}{l_0} = \frac{l'_0 - l_0}{l_0}$$

$$= \frac{401.5 - 400}{400} = 0.0037$$

17. (b)

If the volume is constant, $L_0 =$ Initial length
 $L =$ Final length

$$\Rightarrow \frac{\pi}{4} d^2 L = \frac{\pi}{4} d_0^2 L_0$$

$$\frac{L}{L_0} = \left(\frac{d_0}{d} \right)^2$$

$$\text{True strain, } \epsilon_t = \int_{L_0}^L \frac{dL}{L} = \ln \frac{L}{L_0}$$

$$= \ln \left(\frac{d_0}{d} \right)^2 = 2 \ln \left(\frac{d_0}{d} \right)$$

$$\epsilon_t = 2 \ln \left(\frac{d_0}{d} \right)$$

18. (b)

Proof resilience,

$$u_{\max} = \frac{\sigma_y^2}{2E} = \frac{400^2}{2 \times 2 \times 10^5} = 0.4 \text{ N/mm}^2$$

19. (c)

Option (a): Perfectly plastic (non-strain hardening)**Option (b):** Elastic plastic material**Option (d):** Rigid material

20. (b)

When a force is applied to a material, it deforms. The deformation can easily be measured. Hence, strain can be measured. Whereas, the force that was applied cannot be measured directly and hence, stress cannot be measured directly.

Therefore, although it appears that first a force is applied and then strains are developed in the body due to the applied forces.

But, due to the fact that strain can be measured directly and stress cannot be, strain is a fundamental behaviour of the material while stress is a derived concept.

21. (a)

Fatigue is the weakening of a material caused by repeatedly applied loads. It is the progressive and localized structural damage that occurs when a material is subjected to cyclic loading.





MACHINE DESIGN

OBJECTIVE PRACTICE SETS

Page No. 252 - 332

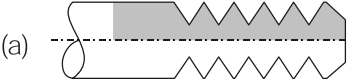
Static and Variable Loading

MCQ and NAT Questions

- Q.1** If the size of a standard specification for a fatigue testing machine is increased, the endurance limit for the material will
- have same value as that of standard specimen
 - increases
 - decreases
 - None of these
- Q.2** Failure of a material is called fatigue when it fails
- at the elastic limit
 - below the elastic limit
 - at the yield point
 - below the yield point
- Q.3** The design of the pressure vessel is based on
- longitudinal stress
 - hoop stress
 - longitudinal & hoop stress
 - none of these
- Q.4** Stress concentration in a machine component of ductile material is not so harmful as it is in brittle material because
- In ductile material local yielding may distribute stress concentration
 - Ductile material has larger Young's Modulus
 - Poisson's ratio is larger in ductile materials
 - Modulus of rigidity is larger in ductile materials
- Q.5** The design calculations for members subject to fluctuating loads with the same factor of safety yield the more conservative estimates when using
- Gerber relation
 - Soderberg relation
 - Goodman relation
 - none of the above
- Q.6** The severity of stress-concentration can be reduced
- by using multiple notches
 - by removal of undesired materials
 - by drilling additional holes
 - by all of the above
- Q.7** Which of the following threaded joint will give the minimum stress concentration result?
- 
 - 
 - 
 - 
- Q.8** S-N curve is valid for
- Ferrous material only
 - Non-ferrous materials
 - Both the ferrous & non-ferrous materials
 - None of the above
- Q.9** The maximum stress due to stress concentration in a bar having circular transverse hole as compared to its static stress without hole will be
- remain same
 - 2 times
 - three time
 - four times
- Q.10** Surface fatigue failure which occurs when the load on the gear tooth exceeds the surface endurance strength of the material, is known as
- Destructive pitting
 - initial pitting
 - Scoring
 - Corrosive wear
- Q.11** Consider the following statements
- Stress concentration factor (SCF) are used for ductile material under static loading.
 - SCF are used for brittle materials under static loading.
- Which of the above statements is/are correct
- 1 only
 - 2 only
 - Both 1 & 2
 - Neither 1 nor 2

Q.12 Consider the following surface finish on steel components:

1. Polished
2. Machined & cold drawn
3. Hot rolled
4. Forged

Correct sequence of surface finish factor in ascending order for above finish is

- (a) 1-2-3-4
- (b) 2-3-4-1
- (c) 3-4-1-2
- (d) 4-3-2-1

Q.13 Consider following statements about low cycle and high cycle fatigue:

1. Low cycle fatigue corresponds to stress cycle less than 1000.
2. High cycle fatigue corresponds to stress cycle more than 10000.
3. The machine components such as springs, ball bearings, gears etc. are subjected to high cycle fatigue.
4. A greater factor of safety is taken in low cycle fatigue to ignore the fatigue effect.

Which of the above statements are valid?

- (a) 1, 2, 3 and 4
- (b) 2, 3 and 4
- (c) 1, 3 and 4
- (d) 1 and 3

Q.14 Increase of actual stress over nominal stress due to stress raising notches in fatigue loading is given by

- (a) $K_f \sigma_0$
 - (b) $K_t \sigma_0$
 - (c) $(K_f - 1) \sigma_0$
 - (d) $(K_t - 1) \sigma_0$
- (All symbols have their usual meaning)

Q.15 Consider the following figure and match the following:

List-I

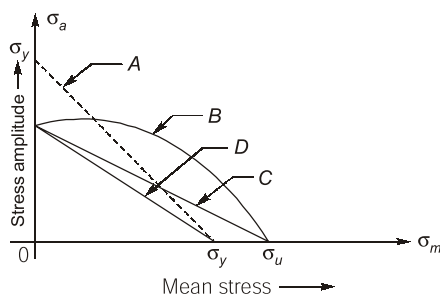

List-II

1. Gerber line
2. Soderberg line
3. Failure line
4. Fatigue line
5. Goodman line
6. Yield line

Codes:

- | | A | B | C | D |
|-----|---|---|---|---|
| (a) | 3 | 2 | 5 | 1 |
| (b) | 6 | 1 | 5 | 2 |
| (c) | 3 | 1 | 5 | 4 |
| (d) | 6 | 5 | 2 | 4 |

Q.16 Notch sensitivity factor is defined as the ratio of

- (a) Actual stress to theoretical stress.
- (b) Increase of actual stress over nominal stress to increase of theoretical stress over nominal stress.
- (c) Theoretical stress to actual stress.
- (d) Increase of theoretical stress over nominal stress to increase of actual stress over nominal stress.

Q.17 A high factor of safety is chosen under the following conditions:

1. Exact mode of failure of the component is unpredictable.
2. There is stress concentration in a machine component.
3. High reliability is demanded in applications like components of aircraft.
4. There is possibility of residual stresses in the machine component.

Which of the above statements are correct?

- (a) 1, 2 and 3 only
- (b) 1, 3 and 4 only
- (c) 2, 3 and 4 only
- (d) 1, 2, 3 and 4

Q.18 A fatigue stress concentration factor of 1 means

- (a) material is fully sensitive to notches.
- (b) material has no sensitivity to notches
- (c) theoretical stress concentration factor is equal to zero
- (d) theoretical stress concentration factor is equal to fatigue stress concentration factor

Q.19 What is the maximum stress induced at the edge of an elliptical hole of major axis 20 and minor axis 15 in a flat plate, as shown in figure?

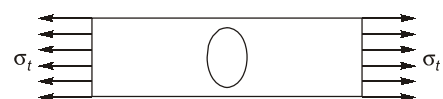

- (a) $2.67 \sigma_t$
- (b) $2.33 \sigma_t$
- (c) $3 \sigma_t$
- (d) $3.67 \sigma_t$

Q.20 Consider the following statement:

1. Maximum principal stress theory is used in brittle material.
2. Maximum shear stress theory is used in ductile material.
3. Distortion energy theory is the most conservation theory.

Which of the above statements is/are correct?

- (a) 1 only (b) 3 only
(c) 1, 2 and 3 (d) 1 and 2

Q.21 If theoretical and fatigue stress concentration factor are 2 and 1.5 respectively. The notch sensitivity is

- (a) 0.4 (b) 0.1
(c) 0.5 (d) 0.75

Q.22 A cast steel machine component having a theoretical stress concentration factor of 3.1 and notch sensitivity of 0.7 then its effect on endurance limit is:

- (a) 59.515% increment
(b) 59.515% reduction
(c) 40.485% increment
(d) 40.485% reduction

Q.23 Consider the following statements regarding fatigue :

1. It is the phenomenon of failure or fracture under fluctuating stresses.
2. It is phenomenon of failure or fracture under static stresses.
3. It is phenomenon of decrease in resistance of material under variable or cyclic loading.

Which of the above statements is/are correct?

- (a) 1 only (b) 1 and 2
(c) 3 only (d) 1 and 3

Q.24 The S-N curve is the graphical representation of stress amplitude versus the number of stress cycles before the fatigue failure on a

- (a) log-log graph paper
(b) cartesian co-ordinate system
(c) semilog graph paper
(d) cylindrical co-ordinate system

Q.25 A machine component that is subjected to fluctuating stress which varies from 50 to 100 N/mm². The corrected endurance limit and

ultimate strength are 270 MPa and 600 MPa respectively. The factor of safety, using Gerber theory is

- (a) 2.5 (b) 5.5
(c) 7.5 (d) 9.5

Q.26 A rectangular plate of a width 10 mm & thickness 3 mm with a transverse hole of 2.5 mm in tension of 15 kN. The nominal stress is

- (a) 6.67 N/mm² (b) 66.67 N/mm²
(c) 666.67 N/mm² (d) 6666.67 N/mm²

Q.27 A coil chain of a crane required to carry a maximum load of 100 kN, is shown in following figure.

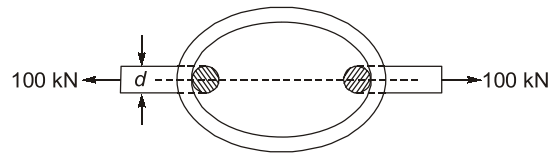

What is the diameter of the link stock, if the permissible tensile stress in the link material is not to exceed 150 MPa?

- (a) 20 mm (b) 25 mm
(c) 30 mm (d) 35 mm

Q.28 A cast iron link, as shown in following figure, is required to transmit a steady tensile load of 50 kN. What is the maximum tensile stress induced?

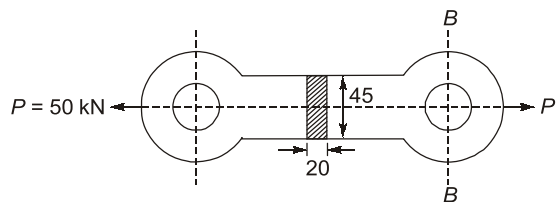

(All dimensions in mm)

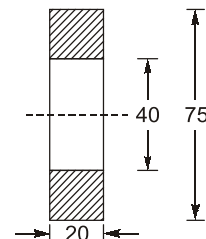

(Section B-B)

- (a) 55.55 MPa (b) 60 MPa
(c) 64.5 MPa (d) 71.42 MPa

Q.29 A pull of 80 kN is transmitted from a bar X to the bar Y through a pin as shown in following figure. If the maximum permissible tensile stress in the bars is 100 N/mm² and the permissible shear

Answers Static and Variable Loading

1. (c) 2. (d) 3. (b) 4. (a) 5. (b) 6. (d) 7. (d) 8. (a) 9. (c)
 10. (a) 11. (b) 12. (d) 13. (c) 14. (c) 15. (b) 16. (b) 17. (d) 18. (b)
 19. (d) 20. (d) 21. (c) 22. (b) 23. (d) 24. (a) 25. (b) 26. (c) 27. (c)
 28. (d) 29. (b) 30. (c) 31. (b) 32. (b) 33. (c) 34. (d) 35. (d) 36. (a)
 37. (a) 38. (c) 39. (d) 40. (a) 41. (a) 42. (4) 43. (1.47) 44. (1.6) 45. (159.617)
 46. (140) 47. (1000) 48. (9636.593) 49. (15.81) 50. (9.82) 51. (a, b, c) 52. (a, c) 53. (a, b, d)
 54. (a, c, d) 55. (a, c) 56. (a, b, c, d)

Explanations Static and Variable Loading

1. (c)
 In fatigue testing machine, the rotating beam specimen is small with 7.5 mm diameter. The larger the machine part, the greater the probability that a flaw exists somewhere in the component. The chances of fatigue failure originating at any one of these flaws are more. The endurance therefore reduces with increasing size of the component.

2. (d)
 It has been observed that materials fail under fluctuating stresses at a stress magnitude which is lower than the ultimate tensile strength of the material. Sometimes, the magnitude is even lower than the yield strength. Further, it has been found that the magnitude of the stress causing fatigue failure decreases as the number of stress cycles increase.

3. (b)
 In pressure vessels, the maximum stress in circumferential (hoop) stress, so the permissible stress should be less than maximum one, hence the design of pressure vessel is based on hoop stress.

4. (a)
 In ductile materials, when the stress in the vicinity of the discontinuity reaches the yield point, there is plastic deformation, resulting in a redistribution of stresses. This plastic deformation or yielding is local and restricted to a very small area in the component. The effect of stress concentration is more severe in case of brittle materials due to their inability of plastic deformation. Brittle materials do not yield locally and there is no readjustment of stresses at

the discontinuities. Once the local stress at the discontinuity reaches fracture strength, a crack is formed.

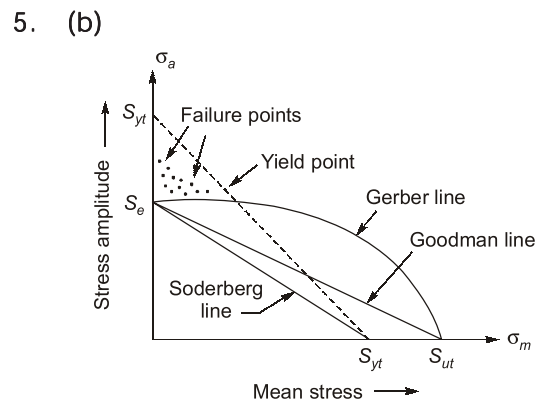

The Soderberg line is a more conservative failure criterion and there is no need to consider even yielding in this case.

